

ZETTLERDISPLAYS

SPECIFICATIONS FOR LIQUID CRYSTAL DISPLAY

CUSTOMER APPROVAL			
※ PART NO. : ATM0880L1(ZETTLER DISPLAYS) SPEC V1.0			
APPROVAL		COMPANY CHOP	
CUSTOMER COMMENTS			

ZETTLER DISPLAYS ENGINEERIN GAPPROVAL		
DESIGNED BY	CHECKED BY	APPROVED BY
XW	GZC	GZH

CONTENTS

DOCUMENT REVISION HISTORY	2
1. GENERAL DESCRIPTIONS	4
2. MECHANICAL SPECIFICATIONS	4
3. INTERFACE SIGNALS	6
4. ABSOLUTE MAXIMUM RATINGS	8
5. ELECTRICAL SPECIFICATIONS	9
5.1 BLOCK DIAGRAM	9
5.2 TYPICAL ELECTRICAL CHARACTERISTICS	10
5.3 RECOMMENDED DRIVING CONDITION FOR LED BACKLIGHT	11
5.4 TIMING CHARACTERISTICS	12
5.5 POWER ON/OFF SEQUENCE.....	16
6. OPTICAL CHARACTERISTICS	17
7. RELIABILITY TESTS / ENVIRONMENTAL	20
7.1 RELIABILITY TEST CONDITIONS	20
7.2 ELECTROSTATIC DISCHARGE (ESD).....	21
8. PACKING REMOVAL AND HANDLING REQUIREMENT	22
9. INCOMING INSPECTION SPEC APPROVAL SHEET	24
10. DEFINITIONS	32
11. LIFE SUPPORT APPLICATIONS	32
12. APPENDIX	32

1. General Descriptions

- 8.8" (diagonal), 8:3, landscape, normally black, ADS, transmissive, amorphous silicon TFT LCD module
- Display Resolution: 1280 x RGB x 480
- Wide viewing angle (U/D/L/R): Free viewing direction
- Display up to 16.7M colours
- 24-bit single port LVDS interface (with T-CON)
- Anti-glare front polarizer and front polarizer absorption axis angle is horizontal, rear polarizer absorption axis angle is vertical.
- White LED backlight
- “RoHS” compliance.

2. Mechanical Specifications

The mechanical detail is shown in Fig. 1 and summarized in Table 1 below.

Table 1

Parameters		Specifications	Unit
Outline dimensions	Width x Height	229.6(W) x 97.3(H) x6.0(T) (no include FPA)	mm
Color TFT 1280 x RGB x 480	Bezel opening	211.48(W) x 80.68(H)	mm
	Active area	209.28(W) x 78.48 (H)	mm
	Display format	1280 x RGB x 480	dots
	Color configuration	RGB Vertical stripes	-
	Dot pitch	(0.0545*3) (W) x 0.1635 (H)	mm
Backlight		LED	-
Weight		Approx:0.28	Kg

ATM0880L1(ZETTLER DISPLAYS)TFT MODULE V1.0

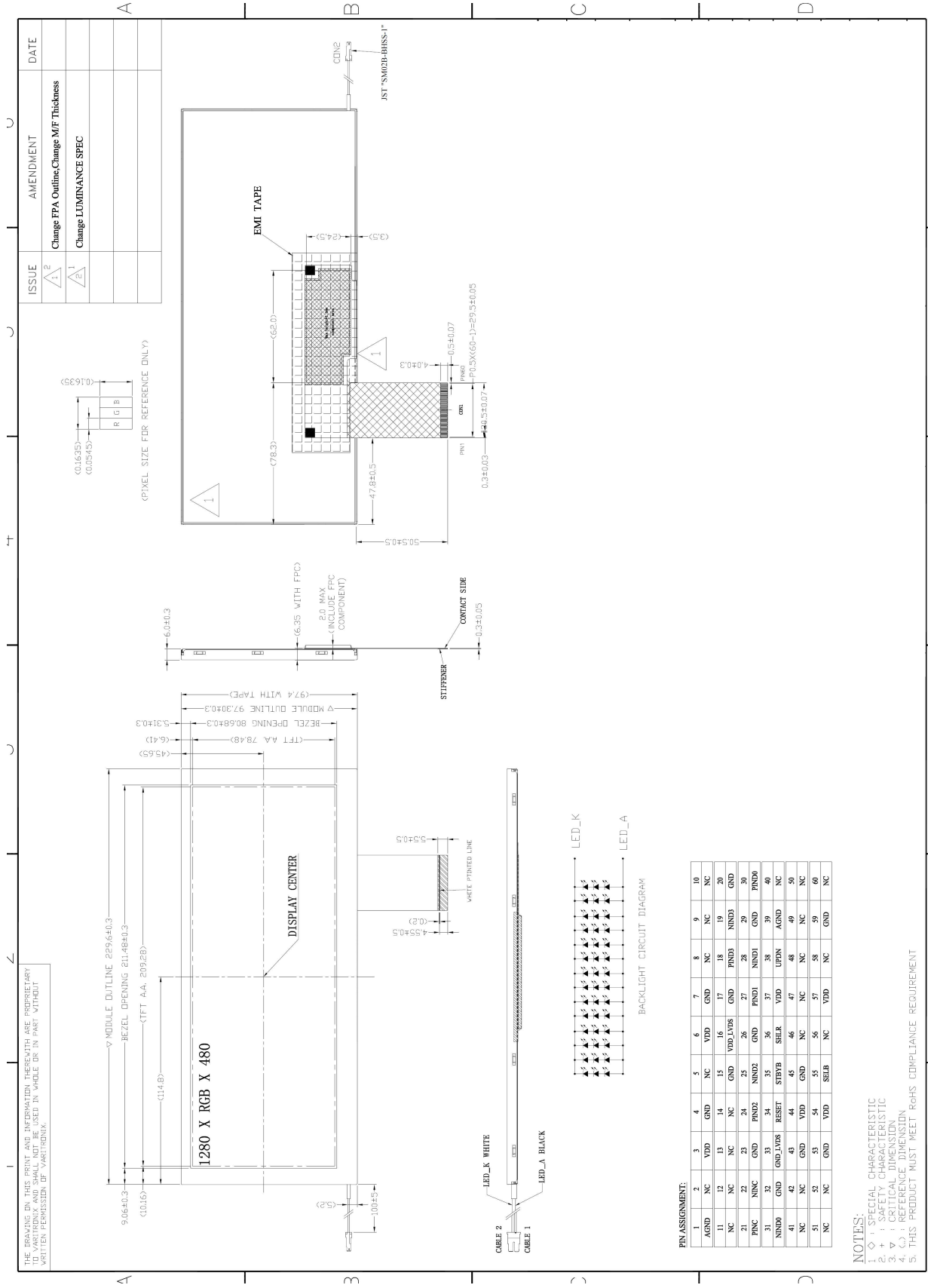

3. Interface Signals

Table 2: Connector Pin assignment

Pin No.	Symbol	I/O	Description	Remarks
1	AGND	P	Analog Ground	
2	NC	-	No connect	
3	VDD	P	Power pin	3.3V typ.
4	GND	P	Ground	
5	NC	-	No connect	
6	VDD	P	Power pin	3.3V typ.
7	GND	P	Ground	
8	NC	-	No connect	
9	NC	-	No connect	
10	NC	-	No connect	
11	NC	-	No connect	
12	NC	-	No connect	
13	NC	-	No connect	
14	NC	-	No connect	
15	GND	P	Ground	
16	VDD_LVDS	P	LVDS Power pin	3.3V typ.
17	GND	P	Ground	
18	PIND3	I	LVDS Data channel 3 +	
19	NIND3	I	LVDS Data channel 3 -	
20	GND	P	Ground	
21	PINC	I	LVDS Clock channel +	
22	NINC	I	LVDS Clock channel -	
23	GND	P	Ground	
24	PIND2	I	LVDS Data channel 2 +	
25	NIND2	I	LVDS Data channel 2 -	
26	GND	P	Ground	
27	PIND1	I	LVDS Data channel 1 +	
28	NIND1	I	LVDS Data channel 1 -	
29	GND	P	Ground	
30	PIND0	I	LVDS Data channel 0 +	
31	NIND0	I	LVDS Data channel 0 -	
32	GND	P	Ground	
33	GND_LVDS	P	Ground of LVDS	
34	RESET	I	Reset Pin	L: Reset H: Normal
35	STBYB	I	Standby Pin	L: Standby H: Normal
36	SHLR	I	Horizontal shift direction selection	H: Left to Right (Default) L: Right to Left
37	VDD	P	Power pin	3.3V typ.
38	UPDN	I	Vertical shift direction selection	H: Top-Bottom (Default) L: Bottom-Top

ATM0880L1(ZETTLER DISPLAYS)TFT MODULE V1.0

Pin No.	Symbol	I/O	Description	Remarks
39	AGND	P	Analog Ground	
40	NC	-	No connect	
41	NC	-	No connect	
42	NC	-	No connect	
43	GND	P	Ground	
44	VDD	P	Power pin	3.3V typ.
45	GND	P	Ground	
46	NC	-	No connect	
47	NC	-	No connect	
48	NC	-	No connect	
49	NC	-	No connect	
50	NC	-	No connect	
51	NC	-	No connect	
52	NC	-	No connect	
53	GND	P	Ground	
54	VDD	P	Power pin	3.3V typ.
55	SELB	I	8/6 bit mode slection	H: 8 bit L: 6 bit
56	NC	-	No connect	
57	VDD	P	Power pin	3.3V typ.
58	NC	-	No connect	
59	GND	P	Ground	
60	NC	-	No connect	

Remarks: For I/O, “I” is Input, “O” is Output. “P” is for Power, and “C” is for passive.

4. Absolute Maximum Ratings

The product or its functions may be subject to permanent damage if it's stressed beyond those absolute maximum ratings listed below. Exposure to absolute maximum rating conditions for extended periods may affect display module reliability.

Table 3: Absolute Maximum Ratings & Environmental Conditions

Item	Symbol	Min.	Max.	Unit
Digital supply voltage	VDD	-0.3	+3.96	V
Digital I/O input signals	V _{IO}	-0.3	VDD+0.3	V
Single LED forward current	I _F	-	35	mA
Total LED forward current	I _F (Total)	-	490	mA
Relative Humidity (at 60°C, Note 3)	RH		90	%
Operating Temperature (Note 2)	Topr	-30	+80	°C
Storage Temperature	Tstg	-40	+85	°C

Note 1: GND=VSS=0V.

Note 2: Panel surface temperature should not exceed 80°C. No performance guarantee below -30°C.

Note 3: No condensation allowed under any condition.

[Caution]

Do not display fixed pattern for prolonged hours because it may develop image sticking on the display.

5. Electrical Specifications

5.1 Block Diagram

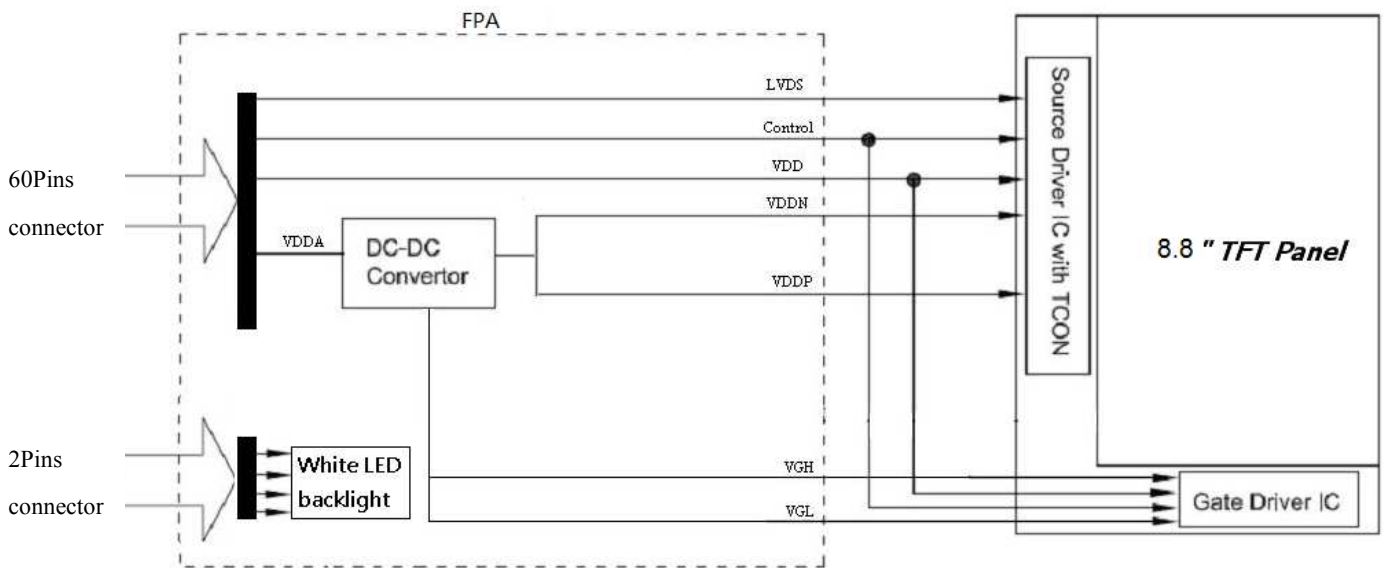

Figure 2: Block Diagram

5.2 Typical Electrical Characteristics

Table 4

Parameter	Symbol	Min.	Typ.	Max.	Unit
Power supply voltage	VDD	3.0	3.3	3.6	V
Power supply current	IVDD (Note 2)	-	140	200	mA
Driver input high signal voltage	V _{IH}	0.7*VDD	-	VDD	V
Driver input low signal voltage	V _{IL}	GND	-	0.3*VDD	
LED Life Time (50%)	(Note 3)	50000	-	-	hrs

Note 1: There is tolerance in optimum LCD driving voltage during production and it will be within the specified range.

Note 2: All white pattern.

Note 3: The “LED Life Time” is defined as the time period when the brightness decrease to 50% of the initial value under continuous lighting at 25°C (dry condition) with the recommended driving current

Table 5 LVDS DC Characteristics

Parameter	Symbol	Min.	Typ.	Max.	Unit
Differential input high Threshold voltage	R _{TH}	+0.15	-	-	V
Differential input low threshold voltage	R _{TL}	-	-	-0.15	V
Differential input common Mode voltage	R _{CM}	1	1.2	1.7- V _{ID} /2	V
LVDS input voltage	V _{INLV}	0.7	-	1.7	V
Differential input voltage	V _{ID}	0.15	-	0.6	V
Differential input leakage Current	R _{VXliz}	-10	-	+10	uA

Single-ended:
LVCLKP(R),
LVCLKN(R),
LVD[3:0]P(R),
LVD[3:0]N(R)

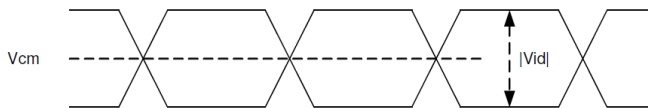

Differential:
LVCLKP(R)-LVCLKN(R),
LVD[3:0]P(R)-
LVD[3:0]N(R)

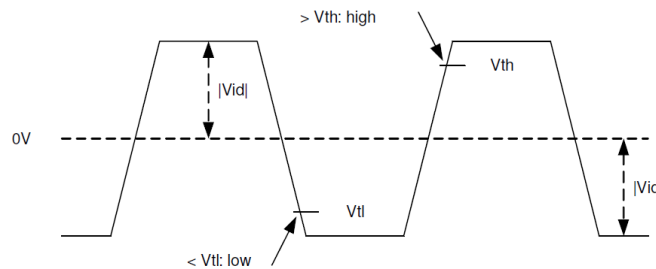

5.3 Recommended Driving Condition For LED Backlight

Table 6

(Ta = 25°C)

Parameter	Symbol	Condition	Min.	Typ.	Max.	Unit	Remark
Supply voltage of LED backlight	V_{LED}	Backlight current = 280 mA Number of LED dies = 42 pcs		9.3		V	Note 1
Supply current of LED backlight	$I_{LED1/14}$	Per LED string	-	20	-	mA	Note 2
Total Supply current of LED backlight	$I_{LEDTotal}$	$I_{LED1} + \dots + I_{LED14}$	-	280	-	mA	Note 2
Backlight Power Consumption	P_{LED}	-	-	2.6	-	W	Note 3

Note 1: Backlight Circuit Diagram

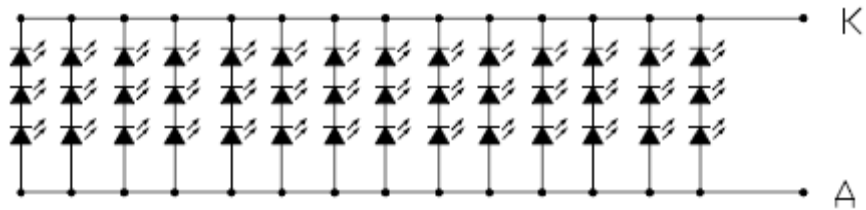

Note 2: The LED driving condition is defined for each LED module.

Total input current = 20 x 14 = 280 mA, and cannot exceed 30 mA for each string.

Note 3: Backlight power consumption is calculated by $I_{LED} (Total) \times V_{LED}$

5.4 Timing Characteristics

5.4.1 LVDS AC electrical characteristics

Table 7: AC Characteristic of LVDS

Parameter	Symbol	Min.	Typ.	Max.	Unit
Clock frequency	FLVCLK	20	-	85	MHz
Clock period	TLVCLK	11.76	-	-	ns
1 data bit time	UI	-	1/7	-	TLVCLK
Clock high time	TLVCH	-	4	-	UI
Clock low time	TLVCL	-	3	-	UI
Position 1	TPOS1	-0.2	0	0.2	UI
Position 0	TPOS0	0.8	1	1.2	UI
Position 6	TPOS6	1.8	2	2.2	UI
Position 5	TPOS5	2.8	3	3.2	UI
Position 4	TPOS4	3.8	4	4.2	UI
Position 3	TPOS3	4.8	5	5.2	UI
Position 2	TPOS2	5.8	6	6.2	UI
Input eye width	TEYEW	0.6	-	-	UI
Input eye border	TEX	-	-	0.2	UI
LVDS wake up time	TENLVDS	-	-	150	us

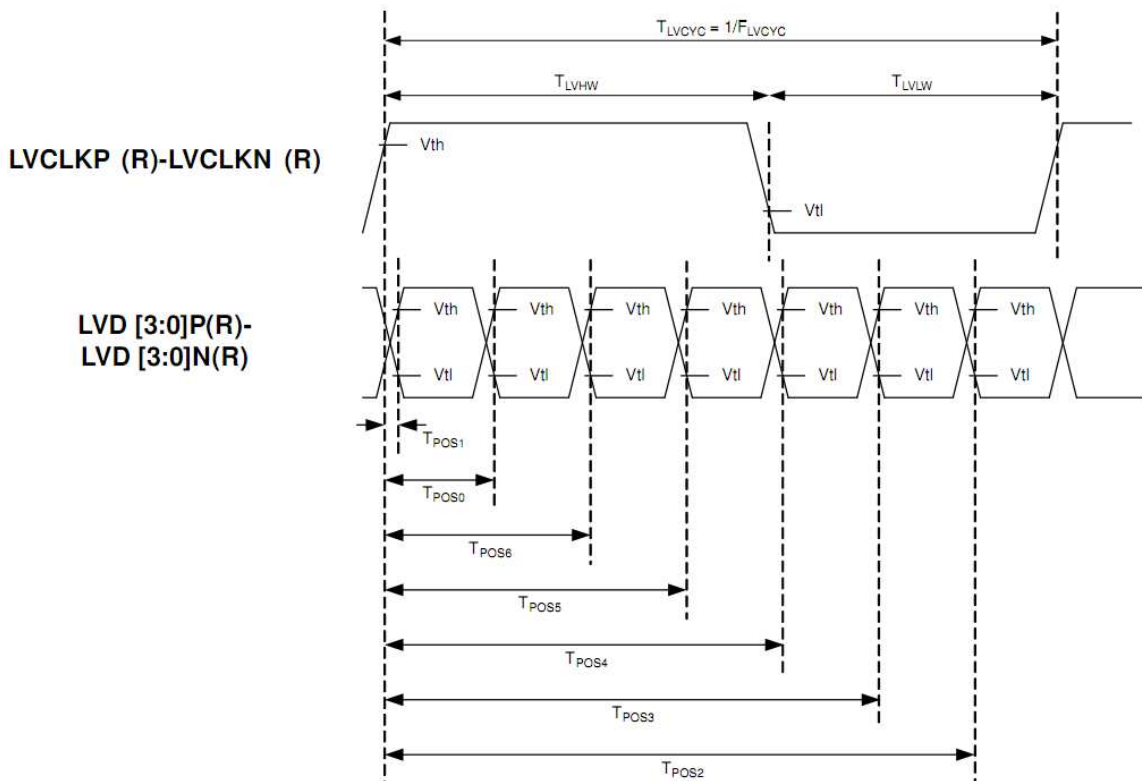

Single-ended:
LVD [3:0]P,
LVD [3:0]N

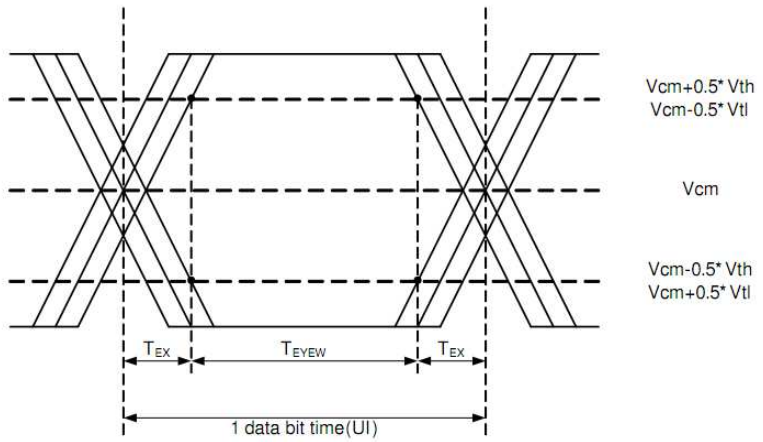

Differential:
LVD [3:0]P-LVD [3:0]N

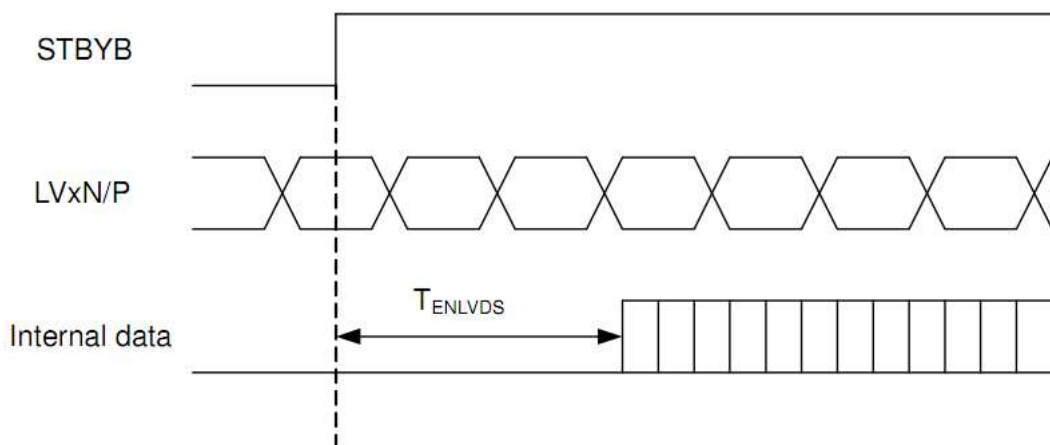
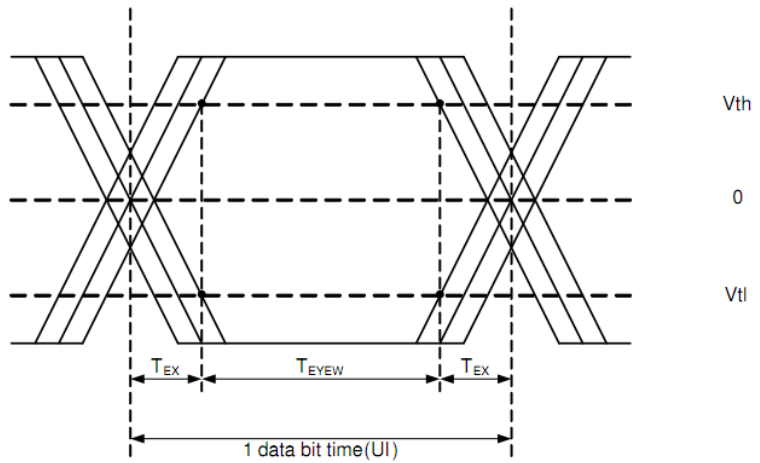

5.4.2 LVDS Input Format

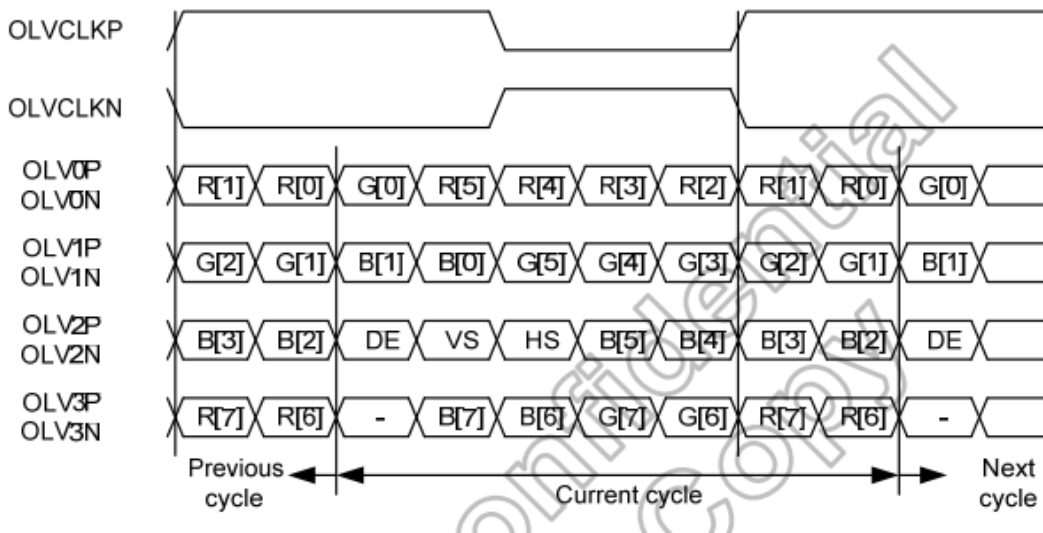
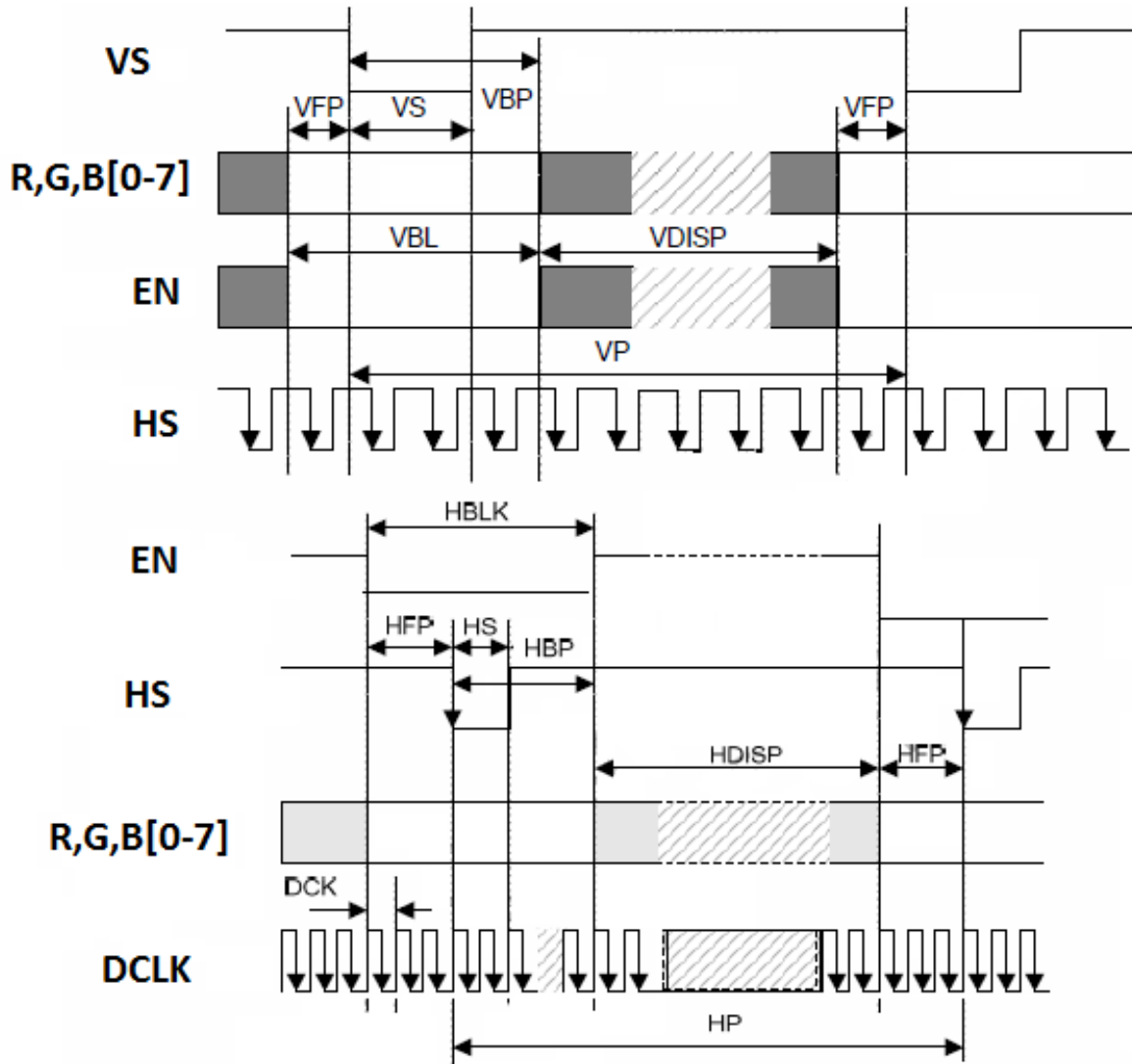

Figure 3: 1-port LVDS signals, VESA format, 8-bit mode

5.4.3 Video Signal Timing

Table 8: Video signal timing

Symbol	Parameter	Conditions	Related Pins	Min.	Typ.	Max.	Unit
VP	Vertical Total	-	VSYNC	487	493	624	Line
VS	VSYNC Low Pulse Width	-	VSYNC	1	3	20	Line
VBP	Vertical Back Porch	-	VSYNC	2	5	255	Line
VFP	Vertical Front Porch	-	VSYNC	5	8	260	Line
VDISP	Vertical Active Area	-	VSYNC, HSYNC	-	480	-	Line
HP	Horizontal Total	-	HSYNC	1309	1322	1664	
HS	HSYNC Low Pulse Width	-	HSYNC	10	12	255	DCK
HBP	Horizontal Back Porch	-	HSYNC	5	16	255	DCK
HFP	Horizontal Front Porch	-	HSYNC	24	26	260	DCK
HDISP	Horizontal Active Area	-	HSYNC	-	1280	-	DCK
F _{frame}	Frame Frequency	-	CLK	-	60	-	Hz
f _{CLK}	CLK frequency	-	CLK	38.2	39.1	62.3	MHz



5.5 Power On/Off Sequence

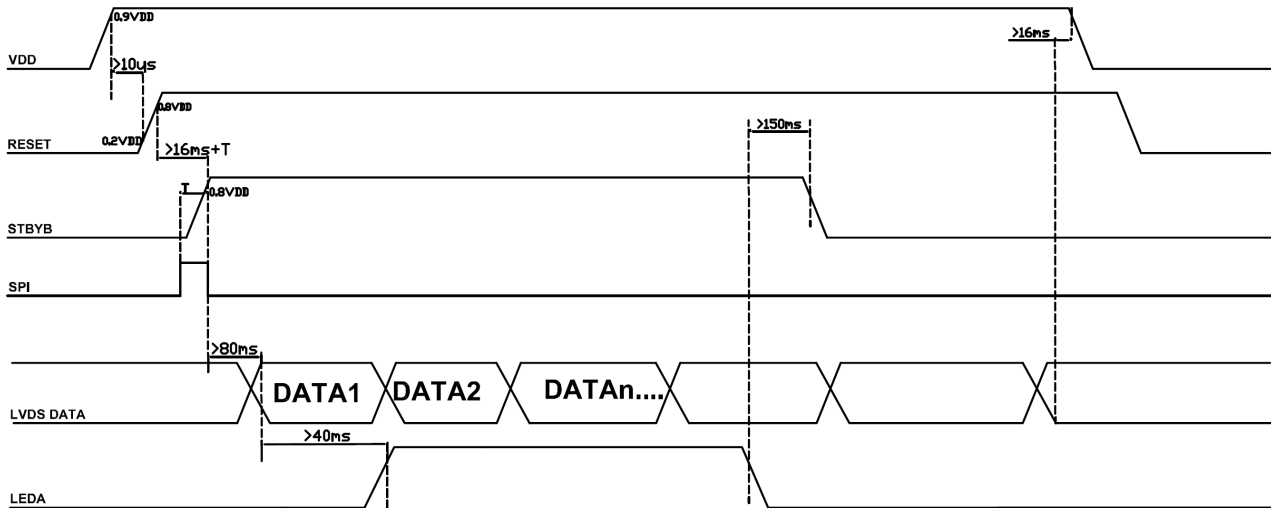

Figure 4: Power-on/Off sequence

6. Optical Characteristics

Conditions unless specified otherwise:

- $T_a = 25^\circ\text{C}$
- Supply voltage = 3.3 volts
- Elapsed time from switch on is greater than 30 minutes
- RGB, white and black test patterns only
- Factory settings
- Brightness = 100% unless specified
- Measurements are conducted at ambient temperature and perpendicular unless specified

Table 9

Items		Symbol	Condition	Min.	Typ.	Max.	Unit	Note	
Response Time		T_{R+T_F}	$T_a = 25^\circ\text{C}$	Viewing normal angle $\theta = \phi = 0^\circ$	-	35	ms	(Note 1)	
			$T_a = -30^\circ\text{C}$		-	-	700		ms
Viewing Angle	Horizontal	θ_3	CR>10	75	85		-	(Note 2)	
		θ_9		75	85				
	Vertical	θ_{12}		75	85				
		θ_6		75	85				
Contrast Ratio		CR	$T_a = 25^\circ\text{C}$	600	1000	-	-	(Note 3)	
Chromaticity	White	x_W	$T_a = 25^\circ\text{C}$	Viewing normal angle $\theta = \phi = 0^\circ$	0.247	0.287	0.327	-	(Note 4)
		y_W			0.249	0.289	0.329	-	
	Red	x_R			0.590	0.630	0.670	-	
		y_R			0.295	0.335	0.375	-	
	Green	x_G			0.280	0.320	0.360	-	
		y_G			0.576	0.616	0.656	-	
	Blue	x_B			0.108	0.148	0.188	-	
		y_B			0.010	0.050	0.090	-	
Brightness		L		300	400	-	cd/m ²		
Luminance Uniformity		ΔY_9	$T_a = 25^\circ\text{C}$	9 Points	70	-	-	%	(Note 5)
NTSC Ratio		-	$T_a = 25^\circ\text{C}$	-	-	70	-	-	%

Note 1: The electro-optical response time measurements shall be made as Figure 5 by switching the “data” input signal OFF and ON. The times needed for the luminance to change from 10% to 90% s T_r , and 90% to 10% is T_f .

Figure 5: Response Time Testing

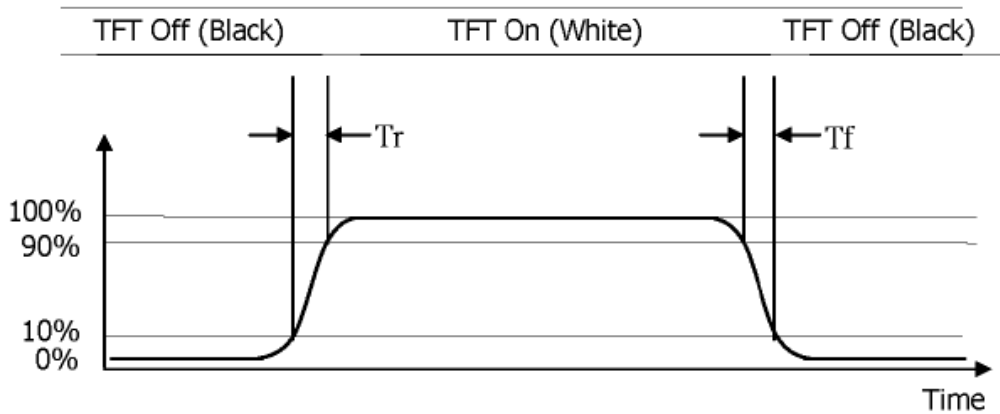

Note 2: The definitions of viewing angle.

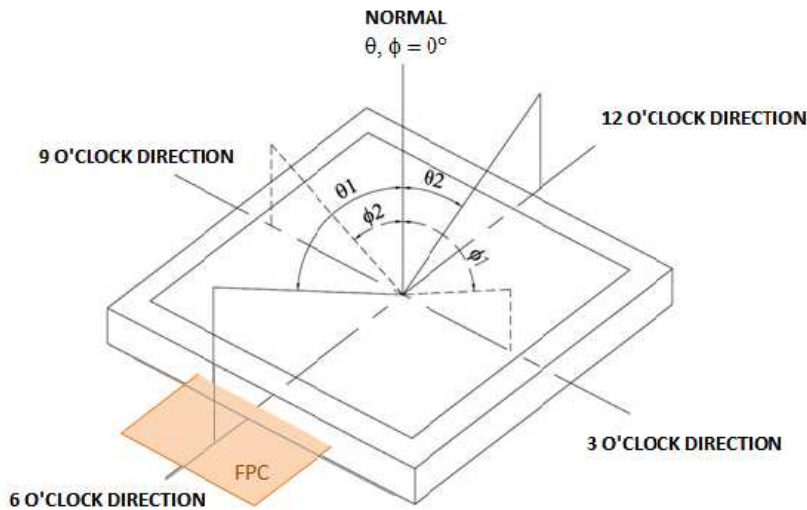

Figure 6: ISO-Contrast Plot (for reference) ($T_a = 25^{\circ}\text{C}$)

Note 3: Contrast measurements shall be made at viewing angle of $\theta=0^{\circ}$ and at the center of the LCD surface by using DMS. Luminance shall be measured with all pixels in the view field set first to white, then to the dark (black) state.

Luminance Contrast Ratio (CR) is defined mathematically.

$$CR = \frac{\text{Luminance when displaying a white raster}}{\text{Luminance when displaying a black raster}}$$

Note 4: The color chromaticity coordinates specified in Table 11 shall be measured at the center of the panel.

Note 5: Uniformity measurement shall be taken at the locations shown in FIG. 7, for a total of the measurements per display, measure surface luminance of these nine points across the LCD surface 50cm from the surface with all pixels displaying white.

$$\text{Uniformity } \Delta Y = \frac{\text{Minimum Luminance of 9 points}}{\text{Maximum Luminance of 9 points}} \times 100 (\%)$$

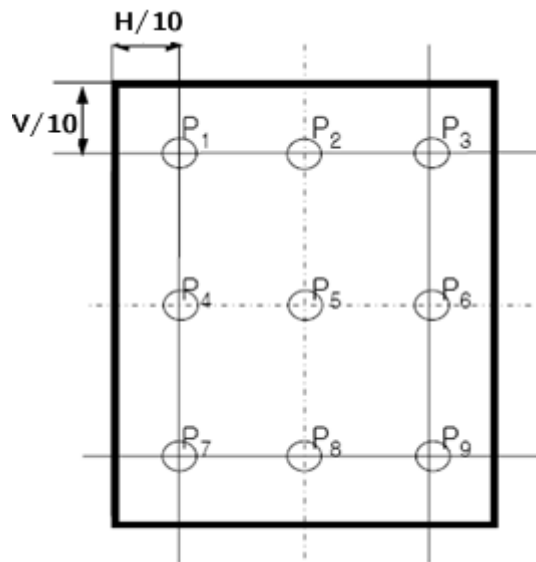

Figure 7: Uniformity Measurement Locations

7. Reliability Tests / Environmental

7.1 Reliability Test Conditions

Table 10: List of Reliability Tests

Test		Symbol	Condition	Reference	Sample Qty
1	High Temperature Storage	HST	+85°C / 240 hrs	IEC 60068-2-2 Bb	4pcs
2	Low Temperature Storage	LST	-40°C / 240 hrs	IEC 60068-2-1 Ab	4pcs
3	High Temperature Operating ^(Note1)	HOT	+80°C / 240 hrs	IEC 60068-2-2 Bb	4pcs
4	Low Temperature Operating ^(Note2)	LOT	-30°C / 240 hrs	IEC 60068-2-1 Ab	4pcs
5	Accelerated Humidity Test Operating	AHTO	+60°C / 90% RH / 240 hrs	IEC60068-2-78 Cab	4pcs
6	Temperature Shock Test	TST	-30°C \diamond +80°C, 30min/5min/30min,200cycles Non-Operating	IEC 60068-2-14Na	4pcs
7	UV exposure resistance	UV	1KW Xenon / 100 hrs Power off.	IEC 60068-2-5 Sa	4pcs
8	Mechanical Shock (Note 2)	-	3 directions: X,Y,Z axes Repeats:6 Peak acc.:10 G Pulse duration: 6 ms (half sine wave) Non-Operating	IEC 60068-2-27Ea	4pcs
9	Mechanical Vibration (Note 2)	-	3 directions: X,Y,Z axes Sweep time: 10 (1Oct/ min) Frequency: 10 -> 150->10 Hz 10-58 Hz: constant amplitude 0.75mm peak. 58-150Hz: constant acceleration 10g peak Sinusoidal, Non-Operating	IEC 60068-2-6Fc	4pcs
10	Image Sticking	-	Burn in: Check pattern 1hrs@ 65°C Inspection Pattern: 50% grey Perpendicular, \leq level 2		4pcs

Note 1: LCD panel surface temperature should not exceed 80°C.

Note 2: No performance guarantee below -30°C.

Note 3: For module internal structure robustness test purpose only. Customer application cluster design should take care of overall mounting robustness with display module.

7.2 Electrostatic Discharge (ESD)





Table 11: ESD Test Conditions





Test	Condition	Method	Remark	Sample Qty
Human body model	R = 330Ω, C = 150pF, <ul style="list-style-type: none"> • Air discharge: ±15 KV to display surface • Contact discharge: ±8 KV to metal frame 	IEC61000-4-2	CLASS B	4pcs
Machine model	R = 0Ω, C = 200pF, ±200V to I/O pins	MIL-STD-883, method 3015	Not operating	4pcs

Note 1: The TFT-LCD panel and IC on module are sensitive to electrostatic discharge; please make sure equipments and operators are properly ground before and during handling

Note 2: As different customer application have different interfacing designs and assembly processes, the display module has no ESD protection circuitry. Customer is required to take special care on ESD level control in the assembly and test processes

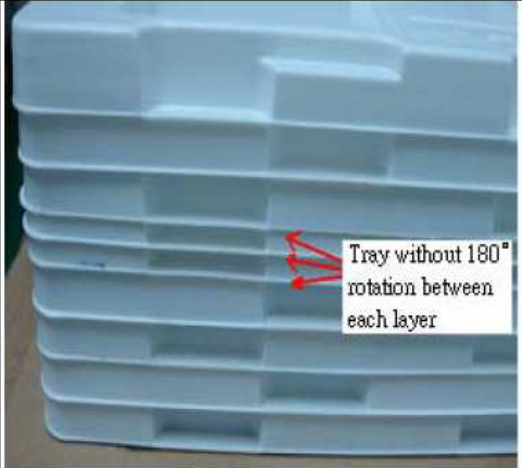
8. Packing Removal and Handling Requirement

Requirement	Wrong	Correct
<p>Get one package each times & hold the package by both hands with proper ESD shielding</p>	 <p>Without ESD gloves and ESD belt</p> <p>Hold the modules by one hand and without proper ESD shielding (Fail)</p>	 <p>Anti ESD gloves Anti ESD belt</p> <p>Hold the modules by both hands (Pass)</p>
<p>Prohibit to stack inner package over 3 layers</p>	 <p>Over 3 layers (Fail)</p>	 <p>Not exceed 3 layers (Pass)</p>
<p>Total packing tray height must within 40 cm</p>	 <p>packing tray over 40 cm</p> <p>Over 40 cm (Fail)</p>	 <p>40 CM</p> <p>Lower than 40 cm (Pass)</p>

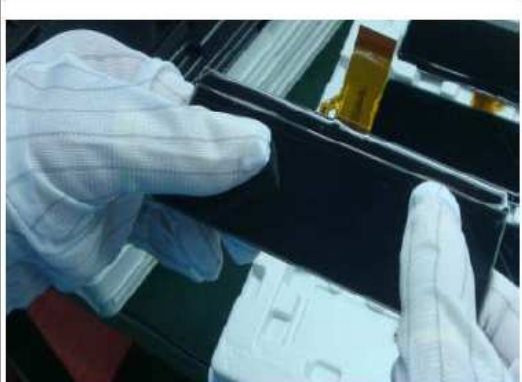
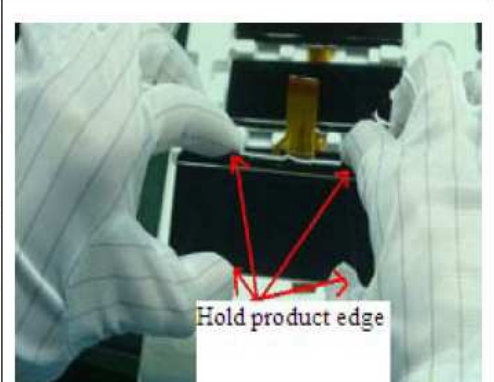
Requirement	Wrong	Correct
<p>Packing tray must rotate 180° in each layer when stack together</p>	 <p>Tray without 180° rotation between each layer</p> <p>Tray without 180° rotation, It will have pressure on the module (Fail)</p>	 <p>Equal spacing</p> <p>Tray with 180° rotation (Pass)</p>
<p>Prohibit to touch product surface by fingers</p>	 <p>Fingers can not touch Product surface</p> <p>Hold product and touch its surface (Fail)</p>	 <p>Hold product edge by hand (Pass)</p>
<p>During assembly, prohibit to press on product surface by fingers, Must hold the product edges by both hands</p>	 <p>During assembly, press on product surface (Fail)</p>	 <p>Hold product edge</p> <p>During assembly, use both hands to hold Product edge only (Pass)</p>

9. Incoming Inspection Spec Approval Sheet

Content

A: Incoming Inspection Specification

1. Introduction
 - 1.1. Scope
 - 1.2. Incoming Inspection Right
 - 1.3. Operation Instruction
2. Generals
 - 2.1. Sampling Method
 - 2.2. Inspection Environment
 - 2.3. Definitions
3. Inspection Criteria
 - 3.1. Visual Inspection Criteria
 - 3.2. Appearance Inspection Criteria

B: Customer Quality Service Process

A: Incoming Inspection Specification

1.0 Introduction

1.1. Scope

This incoming Inspection Standard shall be applied to TFT-LCD LCD that supplied by VX Optronics Corporation (hereinafter called the "Supplier") to its Customer.

1.2. Incoming inspection Right

The buyer (customer) shall inspect the Module within twenty days of the delivery date (inspection period) at its own cost. The results of the inspection (acceptance or rejection) shall be notified to Supplier .

The buyer may, under commercially reasonable reject procedures, reject an entire lot within the inspection period , such unacceptable Module number in accordance with incoming inspection standard.

Should the buyer fail to notify the result of the inspection to supplier within the inspection period, the buyer's right to reject the Module shall lapse and shall be deemed to have been accepted by the buyer.

1.3. Operation Instruction

1.3.1 Mounting Method

- The panel of the LCD consists of two thin glasses with polarizers which easily get damaged. So extreme care should be taken when handling the LCD.
- Excessive stress or pressure on the glass of the LCD should be avoided. Care must be taken to insure that no torsional or compressive forces are applied to the LCD unit when it is mounted.
- If the customer's set presses the main parts of the LCD, the LCD may show the abnormal display. But this phenomenon does not mean the malfunction of the LCD and should be pressed by the way of mutual agreement.
- To determine the optimum mounting angle, refer to the viewing angle range in the specification for each model.
- Mount a LCD module with the specified mounting parts.

1.3.2 Caution of LCD Handling and Cleaning

- Since the LCD is made of glass, do not apply strong mechanical impact or static load onto it. Handling with care since shock, vibration, and careless handling may seriously affect the product. If it falls from a high place or receives a strong shock, the glass may be broken.
- The polarizers on the surface of panel are made from organic substances. Be very careful for chemicals not to touch the polarizers or it leads the polarizers to be deteriorated.
- If the use of a chemical is unavoidable, use soft cloth with solvent (recommended below) to clean the LCD's surface with wipe lightly.

- IPA(Isopropyl Alcohol),Ethyl Alcohol, Trichlorotrifloroethane
 - Do not wipe the LCD's surface with dry or hard materials that will damage the polarizers and others. Do not use the following solvent.
 - Water, Ketone, Aromatics
 - It is recommended that the LCD be handled with soft gloves during assembly, etc. The polarizers on the LCD's surface are vulnerable to scratch and thus to be damaged by sharp particles.
 - Do not drop water or any chemicals onto the LCD's surface.
 - A protective film is supplied on the LCD and should be left in place until the LCD is required for operation.
 - The ITO pad area needs special careful caution because it could be easily corroded. Do not contact the ITO pad area with HCFC, Soldering flux, Chlorine, Sulfur, saliva or fingerprint. To prevent the ITO corrosion, customers are recommended that the ITO area would be covered by UV or silicon.
- LCD should be stored in static-protective & vacuum polythene bag, please assemble it When it expose to the air within 3 days to avoid ITO corrosion
- Please clean the LCD without ultrasonic to avoid line open.
 - Temperature of clean and bake should be less than 80°C.

1.3.3 Caution Against Static Charge

- The LCD modules use C-MOS LSI drivers, so customers are recommended that any unused input terminal would be connected to Vdd or Vss, do not input any signals before power is turn on, and ground you body, work/assembly area, assembly equipments to protect against static electricity.
- Remove the protective film slowly, keeping the removing direction approximate 30-degree not vertical from panel surface, if possible, under ESD control device like ion blower, and the humidity of working room should be kept over 50%RH to reduce the risk of static charge.
- Avoid the use work clothing made of synthetic fibers. We recommend cotton clothing or other conductivity-treated fibers.
- In handling the LCD, wear non-charged material gloves. And the conducting wrist to the earth and the conducting shoes to the earth are necessary.

1.3.4 Caution For operation

- It is indispensable to drive the LCD within the specified voltage limit since the higher Voltage than the limit causes the shorter LCD's life. An electro-chemical reaction due to DC causes undesirable deterioration of the LCD so that the use of DC drive should avoid.
- Do not connect or disconnect the LCD to or from the system when power is on.
- Never use the LCD under abnormal conditions of high temperature and high humidity.
- When expose to drastic fluctuation of temperature(hot to cold or cold to hot) ,the LCD may be affected; specifically, drastic temperature fluctuation from cold to hot ,produces dew on the LCD's surface which may affect the operation of the polarizer and the LCD.

- Response time will be extremely delayed at lower temperature than the operating temperature range and on the other hand at higher temperature LCD may turn black at temperature above its operational range. However those phenomena do not mean malfunction or out of order with the LCD. The LCD will revert to normal operation once the temperature returns to the recommended temperature range for normal operation.
- Do not display the fixed pattern for a long time because it may develop image sticking due to the LCD structure. If the screen is displayed with fixed pattern, use a screen saver.
- Static electricity (ESD) will damage the panel,. Please make sure that operators wear static-protective glove effectively and working tables & device are effectively grounded during operation and other ESD protective method
- Please place LCD on the tray provided by **VX** while moving it, in order to avoid mechanical damage.
- LCD should be stored in required humidity. Low humidity may add static, while high humidity may corrode the ITO circuit of LCD product.

2.0 Generals

2.1. Inspection Environment

2.1.1. Inspection environment conditions:

a. Room temperature : 22 ± 3 °C

b. Humidity : $65 \pm 20\%$ RH

c. Inspection Ambient Illumination :

White fluorescent lamp light brightness -- 500~1000 Lux (≤ 200 Lux for function test)

2.1.2. Viewing Distance

The distance between the panel and the inspector's eyes shall be at least 50cm

2.1.3. Viewing Angle

performing in front of the panel , All directions for inspecting the sample should be within 45° to perpendicular line.

2.1.4. Inspection Area

Display Area (Active Area)

2.2. Main Defect Definitions

2.2.1 Black / White Spots

Points on display which appear Black/ white

These defects do not vary in size or intensity (contrast) when contrast is varied.

2.2.2. Dark / Bright Lines

Lines on display which appear dark/bright. such as vertical, horizontal, or cross lines.

2.2.3. Bright Dot Defects

Dots(sub-pixels) on display which appear bright in the display area and visible through the 5%ND filter at Black Pattern.

2.2.4. Dark Dot Defects

Dots(sub-pixels) on display which appear dark in the display area at R,G,B Color Pattern.

2.2.5. Mura

Mura on display which appears darker / brighter against background brightness on parts of display area

2.2.6. Visual Inspection

Inspection for Panel when the unit turns on.

2.2.7. Appearance Inspection

External inspection for Panel when the unit turns off.

3.0 Inspection Criteria

3.1. Visual Inspection Criteria

3.1.1

(Dimensional unit: mm)

Items		Details	Inspection Criteria			Type
			C Area	O&B Area	D Area	
Appearance Inspection	Foreign Material /Glass Dent/Spots /Extraneous /Substances	Circular Type	D≤0.15, Ignore 0.15<D≤0.3 ,N≤4 D>0.3, N=0 Distance≥10mm	Ignore	Minor	
		Linear Type	0.05<W≤0.1,L≤2.0,N≤4, W≤0.05, Ignore W>0.1,N=0, L>2.0,N=0 Distance≥10mm			
	Scratch	-	0.05<W≤0.1,L≤2.0,N≤4, W≤0.05, Ignore W>0.1,N=0, L>2.0,N=0 Distance≥10mm	Ignore	Minor	
Visual (Function) Inspection	Foreign Material	Circular Type	D≤0.15, Ignore 0.15<D≤0.3 ,N≤4 D>0.3, N=0 Distance≥10mm	Ignore	Minor	
		Linear Type	0.05<W≤0.1,L≤2.0,N≤4, W≤0.05, Ignore W>0.1,N=0, L>2.0,N=0 Distance≥10mm			
	Dent	-	D≤0.15, Ignore 0.15<D≤0.3 ,N≤4 D>0.3, N=0 Distance≥10mm	Ignore	Minor	
	Pixel Defects	Bright Dot	N = 0	Ignore	Major	
		Dark Dot	N ≤ 4 (Distance≥10mm)			
	Line Defects	Bright Line, Dark Line	Not allowed			
	Abnormal display	-	Not allowed			
Mura	ND filter	5%				

Remark: The determination of all defects is based on the panel with Polarizer.

※ Note 1) Definition of the Area

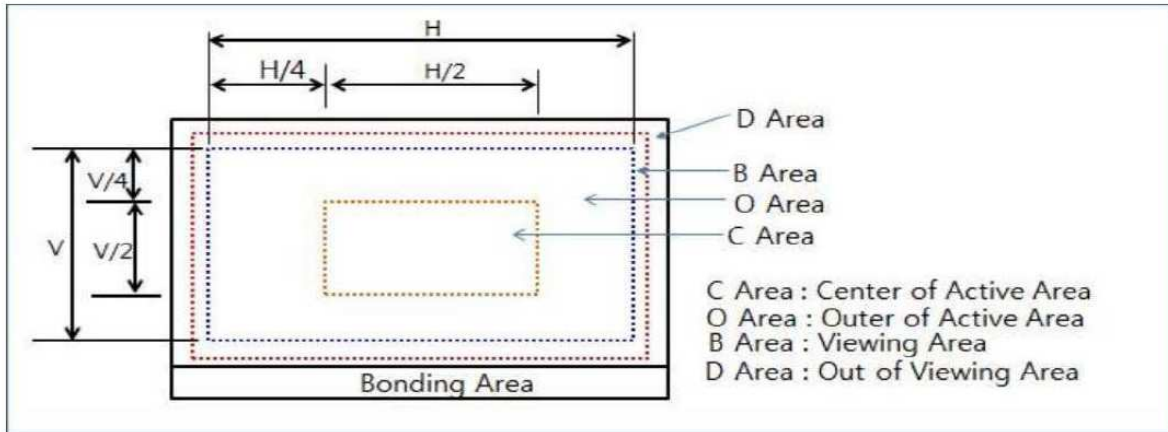

※ Note 2) D = Diameter, L = Length, W = Width, N = Number

$$D = (a + b) / 2$$

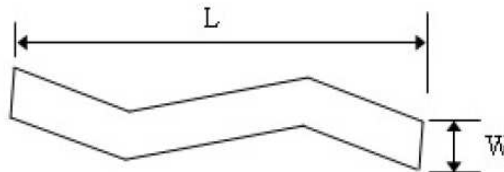
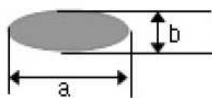

※ Note 3) For pixel defect, dot means a sub-pixel. Dot defects should be larger than half size of a sub-pixel. Dot which is invisible through 5% ND filter or smaller than 1/2 of sub-pixel size will not counted as "1 dot" defect.

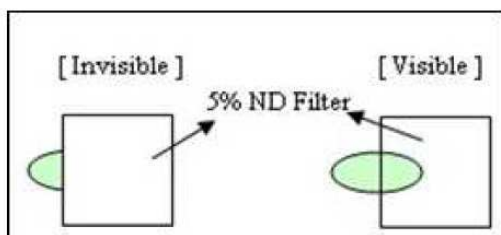

"No dot defect"
(=ignored)

"1 dot defect"
(=counted)

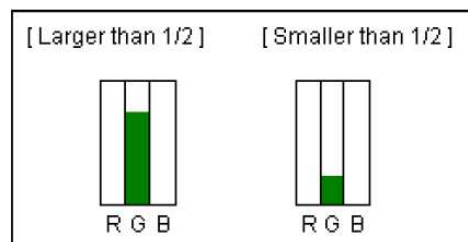

"1 dot defect"
(=counted)

"No dot defect"
(=ignored)

B : VX Customer Quality Service Process

In order to provide better service to Customer, VX shall apply the after-sales product quality service process as below:

- 1.0. According to the P/O from Customer, VX should deliver required product to the place appointed by Customer.
- 2.0. Customer will do IQC for the incoming product.
- 3.0. Inspection standard should be provided by VX, and it will be valid after confirmed by Customer. Inspection and Defects determination should be carried out according to the standard agreed by both Parties.
- 4.0. In order to guarantee in-time communication of product quality information and effective service, QA staff on Customer side should send Weekly Quality Report to the appointed CS staff in VX.
- 5.0.. VX should cooperate with Customer for special quality requirement.
- 6.0. After confirmed by both side, VX should be responsible for the defect products which caused by its quality problem.
- 7.0.. Customer should use the LCD product according to the instruction. VX will not be responsible for the defect product caused by violation of Users' Instruction.
- 8.0. Both parties should deal with the quality problem with friendly cooperative policy.
And both parties should negotiate to deal with the defect products of which the responsibility is not very clear.
- 9.0. The Shelf life of the product is 12 months after the delivery date.

10. Definitions

Data sheet status	
Objective Specification	This data sheet contains target or goal specifications for product development.
Preliminary Specification	This data sheet contains preliminary data; supplementary data may be published later.
Product Specification	This data sheet contains final product specification.
Limiting values	
<p>Limiting values given are in accordance with the Absolute Maximum Rating. Stress above one or more of the limiting values may cause permanent damage to the device. These are stress ratings only and operating of the device at these or any other conditions above those given in the Characteristics sections of the specification is not implied. Expose to limiting values for extended periods may affect device reliability.</p> <p>Device is functional within the limiting conditions doesn't imply the same performance over the covered conditions, customer is required to decide the best range for the final applications.</p>	

11. Life Support Applications

<p>These products are not designed for use in life saving appliances, devices or systems where malfunctioning of these products can reasonably be expected to result in personal injury. Customers using or selling these products for use in such applications do so at their own risk and agree full non liability of Varitronix Limited for any damages or losses resulting from such improper use or sale.</p>
--

12. Appendix